

Section 1



INTRODUCTION TO ARMY LEADERSHIP

Key Points

- 1 What Is Leadership?
- 2 The *Be, Know, Do* Leadership Philosophy
- 3 Levels of Army Leadership
- 4 Leadership Versus Management
- 5 The Cadet Command Leadership Development Program

All my life, both as a soldier and as an educator, I have been engaged in a search for a mysterious intangible. All nations seek it constantly because it is the key to greatness — sometimes to survival. That intangible is the electric and elusive quality known as leadership.

GEN Mark Clark

Introduction

As a junior officer in the US Army, you must develop and exhibit character—a combination of values and attributes that enables you to see what to do, decide to do it, and influence others to follow. You must be competent in the knowledge and skills required to do your job effectively. And you must take the proper action to accomplish your mission based on what your character tells you is ethically right and appropriate. This philosophy of *Be, Know, Do* forms the foundation of all that will follow in your career as an officer and leader. The *Be, Know, Do* philosophy applies to all Soldiers, no matter what Army branch, rank, background, or gender. SGT Leigh Ann Hester, a National Guard military police officer, proved this in Iraq and became the first female Soldier to win the Silver Star since World War II.

Silver Star Leadership

SGT Leigh Ann Hester of the 617th Military Police Company, a National Guard unit out of Richmond, Ky., received the Silver Star, along with two other members of her unit, for their actions during an enemy ambush on their convoy. Hester's squad was shadowing a supply convoy [in March 2005] when anti-Iraqi fighters ambushed the convoy. The squad moved to the side of the road, flanking the insurgents and cutting off their escape route. Hester led her team through the "kill zone" and into a flanking position, where she assaulted a trench line with grenades and M203 grenade-launcher rounds. She and Staff SGT Timothy Nein, her squad leader, then cleared two trenches, at which time she killed three insurgents with her rifle.

When the fight was over, 27 insurgents were dead, six were wounded, and one was captured. Being the first female soldier since World War II to receive the medal is significant to Hester. But, she said, she doesn't dwell on the fact.

"It really doesn't have anything to do with being a female," she said. "It's about the duties I performed that day as a soldier." Hester, who has been in the National Guard since April 2001, said she didn't have time to be scared when the fight started, and she didn't realize the impact of what had happened until much later.

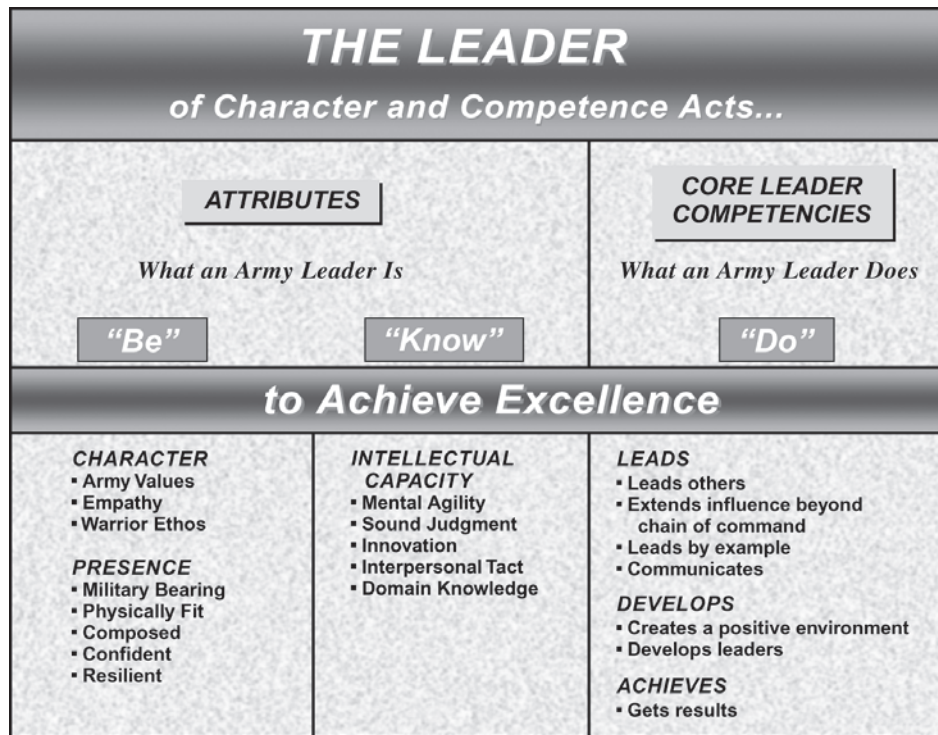

Figure 1.1 The Army’s *Be, Know, Do* Leadership Philosophy

What Is Leadership?

leadership

influencing people—by providing purpose, direction, and motivation—while operating to accomplish the mission and improving the organization

Leadership is the process of influencing people by providing them with *purpose, direction,* and *motivation* while you are operating to accomplish a mission and improve the organization.

An *Army leader* is anyone who, by virtue of assumed role or assigned responsibility, inspires and influences people to accomplish organizational goals. Army leaders motivate people both inside and outside the chain of command to pursue actions, focus thinking, and shape decisions for the greater good of the organization.

Being a leader is a lot more complex than just giving orders. Your influence on others can take many forms. Your words and your deeds, the values you talk about, the example you set, every action you take—on or off duty—are all part of your influence on others.

Providing Purpose and Vision

By providing purpose, you enable your Soldiers to see the underlying rationale for a mission; you provide them the reason to act in order to achieve a desired outcome. Leaders should provide clear purpose for their followers; they do that in a variety of ways. They can use direct means through requests or orders. As time goes on, your subordinates will notice that you communicate in a consistent style of **command** and decision making that builds their trust and confidence. Your Soldiers will eventually be able to read a situation and anticipate your intentions and actions. This trust in turn leads to a cohesive, integrated, and effective unit.

Vision is another way that leaders provide purpose. Vision refers to an organizational purpose that may be broader or have less immediate consequences than other purpose statements. Higher-level leaders carefully consider how to communicate their vision.

command

possession and exercise of the authority to command, a specific and legal position unique to the military—the legal and moral responsibilities of commanders exceed those of any other leader of similar position or authority

Providing Direction

When giving direction, you make clear how you want your Soldiers to accomplish a mission. You prioritize tasks, assign responsibility for completing them (delegating appropriate authority), and make sure subordinates understand the Army standard for the tasks. You decide how to accomplish a mission with the available people, time, and resources. It is your subordinates' job to carry out your orders. But to do that, they need clear direction. Give just enough direction to allow Soldiers to use their initiative, abilities, and imagination—and they will surprise you with the results.

Providing Motivation

Motivation is the will to accomplish a task. By learning about your Soldiers and their capabilities, you will soon be able to gear the team to the mission. Once you have given an order, don't micromanage the process—allow your Soldiers to do their jobs to the best of their abilities. When they succeed, praise them. When they fail, give them credit for the attempt, and coach them on how to improve. Remember that it takes more than just words to motivate. The example you set is at least as important as what you say and how well you manage the work. Stay involved and motivate yourself to attain the best mission result, and your enthusiasm will carry over. A leader's role in motivation is to understand the needs and desires of others, to align and elevate individual drives into team goals, and to influence others and accomplish those larger aims. You'll find that some people have high levels of internal motivation to finish a job, while others need more reassurance and feedback. Motivation spurs initiative when something needs to be accomplished.

The *Be, Know, Do* Leadership Philosophy

The characteristics of an effective Army leader make up the *Be, Know, Do* philosophy. As you have already seen, leadership involves influencing others to take appropriate action. But becoming a leader involves much more. Embracing a leadership role involves developing all aspects of yourself: your character, your competence, and your actions. You learn to lead well by adopting the Army Values, learning military skills, and practicing leadership actions. Only by this self-development will you become a confident and competent leader of character. Figure 1.1 will help you correlate the *Be, Know, Do* philosophy of Army leadership with the *leader attributes* and *core leader competencies*.

Be, Know, Do

the key characteristics of an Army leader that summarize the leader attributes and core leader competencies

TABLE 1.1

The Seven Key Army Values

L Loyalty	Bear true faith and allegiance to the US Constitution, the Army, your unit, and other Soldiers
D Duty	Fulfill your obligations
R Respect	Treat people as they should be treated
S Selfless Service	Put the welfare of the nation, the Army, and subordinates before your own
H Honor	Live up to all the Army Values
I Integrity	Do what is right—legally and morally
P Personal Courage	Face fear, danger, or adversity (physical or moral)

Attributes—What an Army Leader Is

BE: Who You Are—A Leader of Character and a Leader With Presence

Army leadership begins with what the leader must *Be*—the values and attributes that shape character. It may be helpful to think of these as internal and defining qualities you possess all the time. As defining qualities, they make up a leader's identity. Your character is *who you are* and informs everything you do and ask others to do. You demonstrate your commitment to character and to a leadership role in the Army by adopting and living the seven Army Values and the leader attributes. These values form the foundation of your character as a military officer and will guide you in your career. By living the Army Values, you will teach your subordinates by example and help them develop leader attributes.

TABLE 1.2a

The Leader Attributes

1. A Leader of Character (*Identity*)

Factors internal and central to a leader, that which makes up an individual's core

Army Values

- Values are the principles, standards, or qualities considered essential for successful leaders
- Values are fundamental to help people discern right from wrong in any situation
- The Army has set seven values that must be developed in all Army individuals: loyalty, duty, respect, selfless service, honor, integrity, and personal courage.

Empathy

- The propensity to experience something from another person's point of view
- The ability to identify with and enter into another person's feelings and emotions
- The desire to care for and take care of Soldiers and others.

Warrior Ethos

- The shared sentiment internal to Soldiers that represents the spirit of the profession of arms.

2. A Leader With Presence

How a leader is perceived by others based on the leader's outward appearance, demeanor, actions, and words

Military Bearing

- Possessing a commanding presence
- Projecting a professional image of authority.

Physically Fit

- Having sound health, strength, and endurance that support one's emotional health and conceptual ability under prolonged stress.

Composed

- Demonstrating composure and an outward calm through steady control over one's emotions.

Confident

- Projecting self-confidence and certainty in the unit's ability to succeed in whatever it does.

Resilient

- Showing a tendency to recover quickly from setbacks, shock, injuries, adversity, and stress while maintaining a mission and organizational focus.

TABLE 1.2b

The Leader Attributes (continued)

3. A Leader With Intellectual Capacity

The mental resources or tendencies that shape a leader's conceptual abilities and impact effectiveness

Mental Agility

- Flexibility of mind
- The tendency to anticipate or adapt to uncertain or changing situations; to think through second- and third-order effects when current decisions or actions are not producing the desired effects
- The ability to break out of mental “sets” or habitual thought patterns; to improvise when faced with conceptual impasses
- The ability to quickly apply multiple perspectives and approaches to assessment, conceptualization, and evaluation.

Sound Judgment

- The capacity to assess situations or circumstances shrewdly and to draw sound conclusions
- The tendency to form sound opinions and make sensible decisions and reliable guesses
- The ability to make sound decisions when all facts are not available.

Innovation

- The tendency to introduce new ideas when the opportunity exists or in the face of challenging circumstances
- Creativity in producing ideas and objects that are both novel or original and worthwhile or appropriate.

Interpersonal Tact

- The capability to understand interactions with others
- Being aware of how others see you and sensing how to interact with them effectively
- Consciousness of character and motives of others and how that affects interacting with them.

Domain Knowledge

- Possessing facts, beliefs, and logical assumptions in relevant areas
- Technical knowledge—specialized information associated with a particular function or system
- Tactical knowledge—understanding military tactics related to securing a designated objective through military means
- Joint knowledge—understanding joint organizations, their procedures, and their roles in national defense
- Cultural and geopolitical knowledge—understanding cultural, geographic, and political differences and sensitivities.

KNOW: Skills You Have Mastered—A Leader With Intellectual Capacity

Competence in soldiering skills—what you *know*—is as important as good character in your growth as an Army leader. Without it, your command will lack substance. To ask subordinates to perform to standard, you must first master the standard yourself. You must master five types of Army leadership attributes and skills in your training:

- *Mental agility*—having flexibility of mind, a tendency to anticipate or adapt to uncertain or changing situations
- *Sound judgment*—having a capacity to assess situations or circumstances shrewdly and to draw feasible conclusions

Critical Thinking

Discuss the attributes of leadership SGT Hester demonstrated during the ambush in Iraq (see Page 3).

- *Innovation*—the ability to introduce something new for the first time when needed or an opportunity exists
- *Interpersonal tact*—interacting with others and accepting the character, reactions, and motives of oneself and others
- *Domain knowledge*—possessing facts, beliefs, and logical assumptions and an understanding of military tactics related to securing a designated objective through military means.

A natural part of an Army officer's career is the opportunity for advancement and promotion. As you advance in rank and responsibility, you will face many new challenges. Having an understanding of and competence in basic Army skills will give you the ability to tackle these new challenges with confidence.

Core Leader Competencies—What an Army Leader Does

DO: How You Carry out Your Decisions—Leads, Develops, and Achieves

As you have already seen, leadership takes place in action. What you *Do* is every bit as important as the *Be* and *Know* aspects of your Army leadership philosophy. While character and knowledge are necessary, by themselves they are not enough. Leaders cannot be effective until they apply what they know. What leaders *Do*, or leader actions, is directly related to the influence they have on others and on what is done.

While the process of influencing others may seem a little vague or intangible at first, the concept becomes concrete when coupled with *operating actions*. Operating actions are those you take to achieve the short-term goal of accomplishing a mission, such as holding a briefing or conducting a drill. While all direct leaders perform operating actions, the type and scope of such actions become more complex as your rank and level of responsibility change. Moreover, it is a natural part of humans' competitive drive to want to get better and better at what they do. Leaders—in seeking to build morale, unit *esprit de corps*, and performance—strive to improve the Soldiers, facilities, equipment, training, and resources under their command. Nothing speaks more clearly to your subordinates about your commitment to excellence and improvement than your ongoing assessment of the unit's performance and your leading the way toward improvement. Your investment of time, effort, and interest in your subordinates' improved performance will pay dividends in building trust and *esprit de corps*.

esprit de corps

a shared sense of comradeship and devotion to the cause among members of a group, team, or unit

TABLE 1.3

The Core Leadership Competencies

Leads	Leading is all about influencing others. Leaders and commanders set goals and establish a vision, and then must motivate or influence others to pursue the goals. Leaders influence others in one of two ways. Either the leader and followers communicate directly, or the leader provides an example through everyday actions. The key to effective communication is to come to a common or shared understanding.
Develops	Developing the organization involves three competencies: creating a positive environment in which the organization can flourish, preparing oneself, and developing other leaders. The environment is shaped by leaders taking actions to foster working together, encouraging initiative and personal acknowledgment of responsibility, setting and maintaining realistic expectations, and demonstrating care for people—a leader's No. 1 resource.
Achieves	Achieving is the third competency. Ultimately, leaders exist to accomplish those endeavors that the Army has prescribed for them. Getting results, accomplishing the mission, and fulfilling goals and objectives are all ways to say that leaders exist at the discretion of the organization to achieve something of value. Leaders get results through the influence they provide in direction and priorities. They develop and execute plans and must consistently accomplish goals to a high ethical standard.

Levels of Army Leadership

Army leadership positions divide into three levels—*direct*, *organizational*, and *strategic*. The leadership level involves a number of factors, including:

- Span of control
- Headquarters level
- Extent of the influence of the leader holding the position
- Size of the unit or organization
- Type of operations the unit conducts



Figure 1.2 Army Leadership Levels

Oath of Office Taken by Commissioned Officers in the US Army

I [full name], having been appointed a [rank] in the United States Army, do solemnly swear (or affirm) that I will support and defend the Constitution of the United States against all enemies, foreign and domestic; that I will bear true faith and allegiance to the same; that I take this obligation freely, without any mental reservation or purpose of evasion, and that I will well and faithfully discharge the duties of the office upon which I am about to enter. So help me God.

Leader rank or grade may not automatically indicate the position's leadership level, which is why Figure 1.2 contains no ranks.

- Number of people assigned
- The unit's long-term mission or how far in advance it develops plans.

Direct Leadership

Direct leadership is face-to-face, first-line leadership. Subordinates of direct leaders see them all the time at the team, squad, section, platoon, company, battery, squadron, and battalion levels. The direct leader may command anywhere from a handful to several hundred people. Direct leaders influence their subordinates one-on-one, but may still guide the organization through subordinate officers and noncommissioned officers (NCOs). Direct leaders quickly see what works, what doesn't work, and how to address problems.

Organizational Leadership

Organizational leaders command several hundred to several thousand people. Their command is indirect, generally through more levels of subordinates. This "chain of command" sometimes makes it difficult for them to see results. Organizational leaders usually employ staffs of subordinate officers to help manage their organizations' resources. Organizational leaders are responsible for establishing policy and the organization's working climate. Their skills are the same as those of direct leaders, but they cope with more complexity, more people, greater uncertainty, and a greater number of unintended consequences. They have little face-to-face contact with the rank-and-file Soldier and command at the brigade through corps levels. Typically, their focus is on planning and missions in the next two to 10 years.

Strategic Leadership

Strategic leaders include military and Department of the Army (DA) civilian leaders from the major command level through the Department of Defense leadership. Strategic leaders are responsible for large organizations and influence several thousand to hundreds of thousands of people. They establish force size and structure, allocate resources, communicate strategic vision, and prepare their commands for their future roles. Strategic leaders consider the total environment in which the Army functions. They may take into account such things as congressional hearings, Army budgetary constraints, new-systems acquisition, civilian programs, research, development, and interservice cooperation.

Leadership Versus Management

As you can see, leadership operates through a wide range of levels, organization sizes, and conditions. Depending on the course of your career as an officer, your path might lead to almost any of these levels and assignments if you are willing to work hard to develop your character, competence, and behavior. You should prepare to embrace the opportunity for promotion when it arises. This path will also take you on an exciting journey through Army life that will almost always provide fulfilling work. One aspect of your job to which you should pay particular attention is the tendency toward the "management mindset." Granted, much of your work as an Army officer will be managerial: putting people and resources to work in the most efficient ways. And managers and good leaders have much in common as both focus on results.

But as Table 1.4 shows, managers and good leaders differ in how they approach their jobs. For example, managers administer, while leaders innovate. And while leaders, like managers, must also keep the organization running smoothly, as a leader you must constantly ponder the next steps, come up with better ways to accomplish the goal, and creatively engage your subordinates to produce more or better results.

The Art of Delegating Downward

The challenge of command is to empower your subordinate leaders. Give them a task, delegate the necessary authority, and then let them do the work. Check on them frequently enough to keep track of what is going on, but don't get in their way. Your mastery of this skill will improve through practice.

TABLE 1.4

Management vs. Leadership

Managers	Leaders
Administer	Innovate
Maintain	Develop
Control	Inspire
Short-term view	Long-term view
Imitate	Originate
Ask how/when	Ask what/why
Accept status quo	Challenge status quo

In short, leaders continually “push the envelope,” searching for ways to change and improve their commands.

Effective leaders build trust and understanding by encouraging their subordinates to seize the initiative and act. They give their Soldiers room to work. This does not mean allowing them to repeat mistakes—your job is to help your subordinates succeed through empowering and coaching. By providing purpose, direction, and motivation for them to operate in support of the mission, you train them to operate independently. A pure management mindset is never able to *let go and lead*.

The Cadet Command Leadership Development Program

The Cadet Command Leadership Development Program is a process designed to develop leadership skills, including those skills you have just reviewed, within a variety of training and educational environments. It is administered on campus by the professor of military science and during summer training by TAC (Train, Advise, Counsel) officers. As you progress through the ROTC program, you will see a variety of different LDP (Leadership Development Program) assessment tools that focus on the seven Army Values and the 16 leadership dimensions. The Blue Card, the Cadet Evaluation Report, the Officer Evaluation Report, and the Developmental Support Form all share common traits—each drawing on the Army leadership model, which is designed to assist you in maximizing your potential.

You achieve excellence when your Soldiers habitually show discipline and commitment to Army Values. Individuals and organizations pursue excellence to improve. The Army cherishes leaders of character who are good role models, consistently set the example, and accomplish the mission while improving their units. The Cadet Command Leadership Development Program is a preview of the Officer Evaluation System, an ongoing performance assessment of regular Army officers, and gives you a foretaste of how others will help you improve your leadership skills.

Critical Thinking

How are managers different from good leaders? Can you think of examples of each in your own life? Which would you rather be? Explain.

Just as the diamond requires three properties for its formation—carbon, heat, and pressure—successful leaders require the interaction of three properties—character, knowledge, and application. Like carbon to the diamond, character is the basic quality of the leader. But as carbon alone does not create a diamond, neither can character alone create a leader. The diamond needs heat. Man needs knowledge, study, and preparation. The third property, pressure—acting in conjunction with carbon and heat—forms the diamond. Similarly, one’s character, attended by knowledge, blooms through application to produce a leader.

GEN Edward C. Meyer

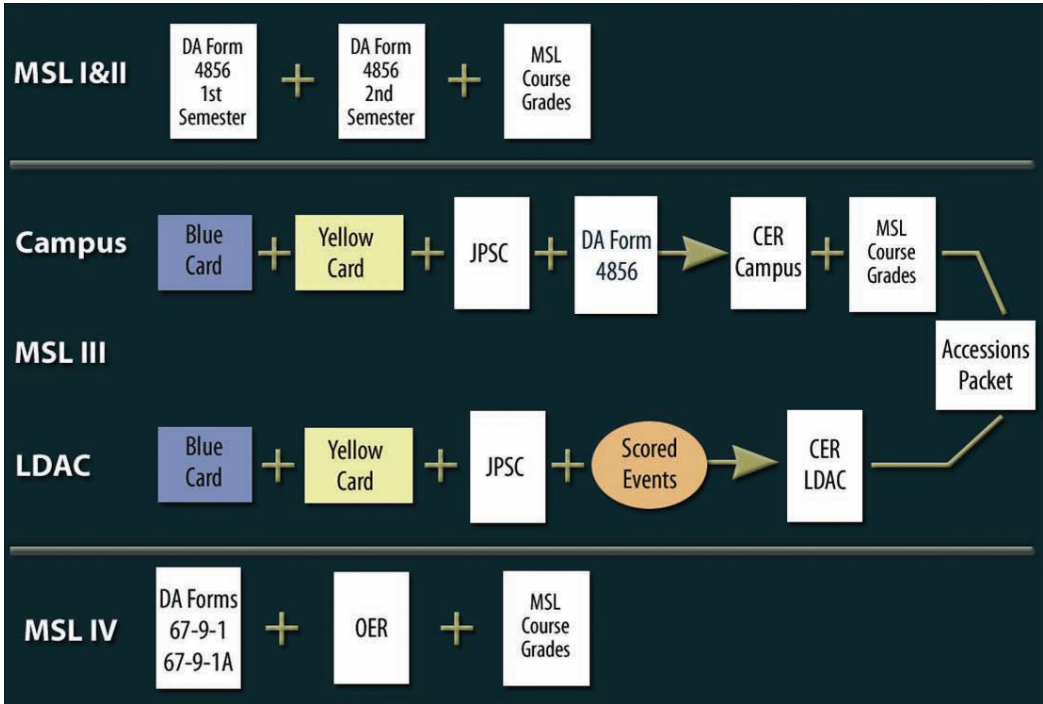

Figure 1.3 LDP Model

Cadet Evaluation Report For use of this form see CC Reg 145-3; staff proponent is USACC DOLD				Type of Report CAMPUS			
PART I - ADMINISTRATIVE DATA							
a. NAME (LAST, FIRST, MIDDLE INITIAL)		b. SSN	c. SEX	d. REGION	e. REGT/CO/PLT		
f. SCHOOL	g. SCHOOL CODE	h. APFT	i. DATE	j. ESTP (Y/N)	k. HEIGHT	l. WEIGHT	
PART II - AUTHENTICATION (Rated cadet's signature verifies cadet has seen completed part I-VI and the administrative data is correct) (Rater & Sr. Rater's signatures verify that the cadet has been counseled)							
a. NAME OF RATER (LAST, FIRST, MI)		b. SSN	c. RANK	d. POSITION	e. SIGNATURE	f. DATE	
g. NAME OF SENIOR RATER (LAST, FIRST, MI)		h. SSN	i. RANK	j. POSITION	k. SIGNATURE	l. DATE	
m. RATER'S TELEPHONE NUMBER			n. SENIOR RATER'S TELEPHONE NUMBER				
o. PERIOD COVERED FROM: TO:			p. SIGNATURE OF RATED CADET		q. DATE		
PART III - LEADERSHIP POSITIONS							
List the evaluated leadership positions from the JPSC (Minimum of 5)							
PART IV - PERFORMANCE DATA							
NOT USED							
PART V - PERFORMANCE EVALUATION - PROFESSIONALISM (Primary Assessor/PLT TAC)							
CHARACTER Disposition of the leader: combination of values, attributes, and skills affecting leader actions							
a. Values - Indicate "S" or "N" for each OBSERVED value "N" Ratings must be justified by observation in Part VI below							
		S	N			S N	
1. LOYALTY (LO): Bears true faith and allegiance to the Constitution, Army, Units and soldier				5. HONOR (HO): Adheres to ARMY'S CODE OF VALUES			
2. DUTY (DU): Fulfills professional, legal and moral obligations				6. INTEGRITY (IT): Exhibits high personal moral standards			
3. RESPECT (RE): Promotes dignity, consideration, fairness and EO				7. PERSONAL COURAGE (PC): Manifests physical and moral courage			
4. SELFLESS SERVICES (SS): Places Army priorities before self							
b. LEADERSHIP ATTRIBUTES/SKILLS/ACTIONS: Place an "X" in the appropriate rating block for dimension within Attributes, Skills, and Actions. "E" and "N" must be justified by observations in Part VI.							
ATTRIBUTES Fundamental qualities and characteristics	1. MENTAL (ME) Posses desire, will, initiative, and discipline	E	S	N	2. PHYSICAL (PH) Maintains appropriate level of physical fitness and military bearing	E S N	
					3. EMOTIONAL (EM) Display self control, calm under pressure	E S N	
SKILLS Skill development is a part of self-development; prerequisite to action	4. CONCEPTUAL (CN) Demonstrates sound judgment, critical /creative thinking, moral reasoning	E	S	N	5. INTERPERSONAL (IP) Shows skill with people coaching, teaching, counseling, motivating, and empowering	E S N	
	7. TACTICAL (TA) Demonstrates proficiency in inquired professional knowledge, judgment, and warfighting	E	S	N		6. TECHNICAL (TE) Possess the necessary expertise to accomplish all tasks and functions	
INFLUENCING Method of reaching goals while operating/improving	8. COMMUNICATING (CO) Display good oral, writing, and listening skills for individuals/ groups	E	S	N	9. DECISION MAKING (DM) Employs sound judgment, logical reasoning, and uses resources wisely	E S N	
					10. MOTIVATING (MO) Inspires, motivates, and guides other toward mission accomplishment	E S N	
OPERATING Short-term mission accomplishment	11. PLANNING/ PREPARING (PL) Develops detailed executable plans that are feasible, acceptable, and executable	E	S	N	12. EXECUTING (EX) Shows tactical proficiency, meets mission standards, and takes care of people resources	E S N	
					13. ASSESSING (AS) Uses after action and evaluation tools to facilitate consistent improvement	E S N	
IMPROVING Long-term improvement in the Army, its people and organizations	14. DEVELOPING (DE) Invests adequate time and effort to develop individual subordinates	E	S	N	15. BUILDING (BD) Spends time and resources improving individuals, teams, groups, and units; fosters ethical climate	E S N	
					16. LEARNING (LR) Seeks self-improvement and organizational growth; envisioning, adapting, and leading changes	E S N	

ROTC CDT CMD FORM 67-9

Figure 1.4a Sample Cadet Evaluation Report

NAME	SSN	PERIOD COVERED FROM	TO
PART VI - PERFORMANCE AND POTENTIAL EVALUATION (PLT TAC/Primary Assessor)			
a. EVALUATE THE RATED CADET'S PERFORMANCE DURING THE RATING PERIOD AND HIS/HER LEADERSHIP POTENTIAL FOR COMMISSIONING			
<input type="checkbox"/>	E-OUTSTANDING PERFORMANCE MUST COMMISSION	<input type="checkbox"/>	S-SATISFACTORY PERFORMANCE COMMISSION
		<input type="checkbox"/>	N-NEEDS IMPROVEMENT BEFORE COMMISSIONING
b. COMMENT ON SPECIFIC ASPECT OF THE PERFORMANCE AND POTENTIAL FOR COMMISSIONING			
c. IDENTIFY ANY UNIQUE PROFESSIONAL SKILLS OR AREAS OF EXPERTISE OF VALUE TO THE ARMY THAT THIS CADET POSSESSES WHICH MAY ASSIST IN DETERMINING BRANCH AND COMPONENT SELECTION			
PART VI - SENIOR RATER (PMS)			
a. EVALUATE THE RATED CADET LEADER POTENTIAL FOR COMMISSIONING			
<input type="checkbox"/>	BEST QUALIFIED	<input type="checkbox"/>	FULLY QUALIFIED
		<input type="checkbox"/>	QUALIFIED
b. PERFORMANCE COMPARE WITH CADETS IN THE SAME UNIT (Campus Only)		c. COMMENT ON PERFORMANCE/POTENTIAL	
<input type="checkbox"/>	BEST QUALIFIED		
<input type="checkbox"/>	FULLY QUALIFIED		
<input type="checkbox"/>	QUALIFIED		
<input type="checkbox"/>	OTHER		
I RANK THIS CADET _____ OF _____			
ROTC CDT CMD FORM 67-9			

Figure 1.4b *continued*



CONCLUSION

Excellence in leadership does not mean perfection. Rather, an excellent leader allows people room to learn from their mistakes as well as savor their successes. Your subordinates will learn to trust that, when they fail—as they will—you will coach them to do better. As you reflect on the Army leader attributes and core leader competencies, developing the skills your position requires, you will become a leader of character and competence. This is the heart of true leadership—**influencing people by providing purpose, direction, and motivation while operating to accomplish the mission and improving the organization.**

You have learned that effective leadership—particularly in field operations—is your primary and most important challenge as an Army officer. You practice values that lead to excellence and develop a team that can prevail in defense of the United States. The Army expects you, as one of its leaders, to **Be, Know, and Do** to the very best of your ability. This model is the keystone for high morale and outstanding performance throughout the entire organization.

Learning Assessment

1. What are the leader attributes and core leader competencies of *Be, Know, Do* in Army leadership?
2. What are the three levels of Army leadership?
3. Explain the difference between leadership and management attributes.
4. Explain how *Be, Know, Do* applies to your daily activities on campus and in ROTC.
5. What are the key components of the Cadet Command Leadership Development Program at the MSL I and II levels?

Key Words

leadership
command
Be, Know, Do
esprit de corps

References

- CCR-145-3, *Reserve Officers Training Corps Precommissioning Training and Leadership Development*. 1 September 2005.
- Field Manual 6-22, *Army Leadership: Competent, Confident, and Agile*. 12 October 2006.
- Wood, S. (17 June 2005). Female Soldier Receives Silver Star in Iraq. *American Forces Press Service*. Retrieved 12 July 2005 from <http://www4.army.mil/ocpa/soldierstories>